

**Black Pine Circle Math Competitions,  
numbers 1 – 7**

# First Annual Math Competition

## Part I

1. A certain Berkeley parking meter gives  $37 \frac{1}{2}$  minutes for 25 ¢. At this rate, how much does 1 hour cost?
2. What is the least common denominator of  $\frac{1}{10}$ ,  $\frac{1}{12}$  &  $\frac{1}{15}$  ?
3. Write  $\frac{1}{27}$  as a decimal.
4. What is the smallest prime larger than 200?
5. How many triangles of all sizes are there in this figure?

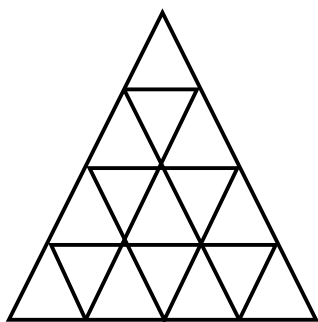

6. A box contains 3 red balls and 1 green ball. A ball is drawn at random and then another is drawn from the remaining balls in the box. What is the chance that both balls drawn will be red?
7. How many 3-letter combinations would come before ABC in the dictionary?
8. One angle of an isosceles triangle is  $50^\circ$ . What is the largest possible remaining angle?
9. How many positive divisors (including 1 and 462) does 462 have?
10. What is the difference between  $19,291^2$  and  $19,289^2$ ?

11. What is the next number in the sequence 1, 2, 4, 7, 11, 16, ... ?
12. A triangle has sides 3, 4, and 5. What is the average of its perimeter and its area?
13. Calculate  $999,999,999^2$ .
14. What is the next number in the sequence 3, 2, 5, 7, 12, 19, ...
15. Let  $P = (1 - \frac{1}{2}) \cdot (1 - \frac{1}{3}) \cdot (1 - \frac{1}{4}) \cdots (1 - \frac{1}{50})$ . What is  $P$ ?
16. Each corner of the shaded square lies on a different side of a larger square, dividing that side into segments of lengths 2 and 3. What is the area of the shaded square?

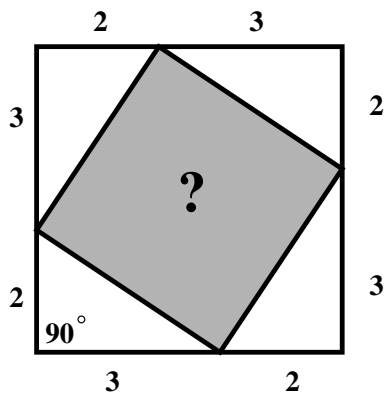

17. A car travels at a distance of 60 miles at 60 MPH and returns the same distance at 30 MPH. What is the car's average speed for the round trip?
18. The license plates of many trucks have 1 letter followed by 5 numbers. How many different such combinations are there?
19. If a clock takes 6 seconds to strike 4:00 and 10 seconds to strike 6:00, how long will it take to strike 10:00?
20. Jim and Jerome each put \$1 into a hat. Jim puts in 2 nickels and 9 dimes while Jerome puts in 6 nickels and 7 dimes. Then Jasper steals a dime. What is the chance it was contributed by Jim?

## Part II

21. Right triangle ACB has legs 6 and 10. What is the length of altitude CD?

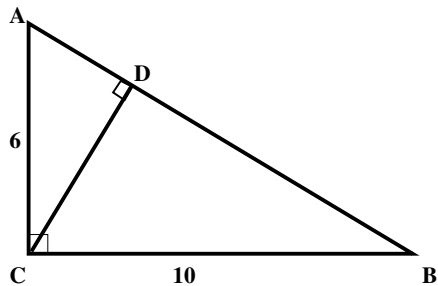

22. Calculate  $243^{-3/5}$ .
23.  $L = \left(\frac{1-31}{1+31}\right) \times \left(\frac{3-31}{3+31}\right) \times \left(\frac{5-31}{5+31}\right) \times \left(\frac{7-31}{7+31}\right) \cdots \times \left(\frac{61-31}{61+31}\right)$ . What is L?
24. A kite is 40 inches long and 30 inches wide. What is the area of the kite in square inches?

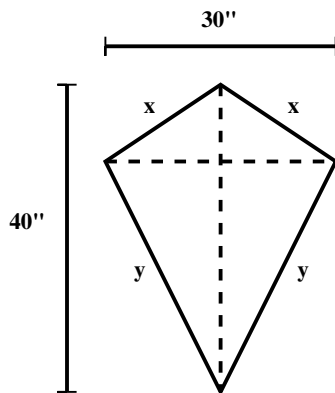

25. Many people are seated around a round table. Each must either always lie or always tell the truth. Each one says that the person on his left is a liar. If the number of people is the cube of a prime, how many people are there?
26. For which values of  $x$  is  $x^2 + 1 \leq 2x$ ?

27. A square garden has a path (shaded region) around it which is 3 feet wide. If the area of the path is 156 square feet, what is the length of the garden?

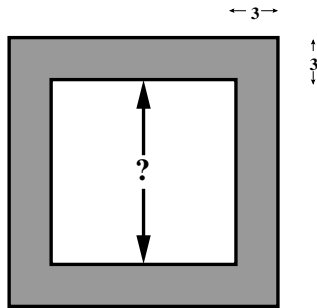

**Area of shaded region = 156**

28. From a single cube, two different edges are randomly chosen. What is the chance they meet at a corner?
29. The distance from Vallejo to Sacramento is 60 miles. A car starts in Vallejo and travels past Sacramento at 60 MPH. A cyclist starts in Sacramento and travels away from Vallejo at 15 MPH. How far from Sacramento will the motorist overtake the cyclist?
30. What is the smallest polynomial divisible by  $(x + 1)$ ,  $(x^2 + 1)$ , and  $(x^4 + 1)$ ?
31.  $\sqrt{7 + 2\sqrt{12}} = \sqrt{a} + \sqrt{b}$ . What are  $a$  and  $b$  if  $a < b$ ?
32. A man is  $2/5$  mile from the entrance of a tunnel, and  $3/5$  mile from the exit. A train approaches the entrance of the tunnel at 45 MPH. If the man runs to either end of the tunnel, he will meet the train there. How fast does the man run?

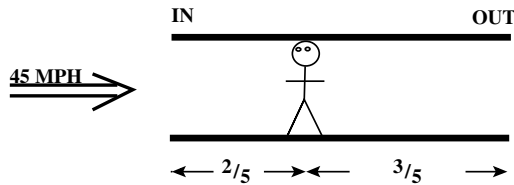

33. Terry and Theotis each receive 1 card from a single deck without jokers. Theotis wins if his card is higher than Terry's and of the same suit. What is the chance that Theotis wins?

34. The number 173, when divided by 2, 3, 5 and 7 leaves the remainders 1, 2, 3 and 5 respectively. What is the next number which leaves these same remainders upon division by 2,3,5 and 7?
35.  $x - 1$  divides evenly in  $x^5 - 4x^3 - 11x^2 + 7x + k$ . What is  $k$ ?
36.  $PA, PB,$  and  $EC$  are tangent to a circle with center  $O$ .  $PE = 6$  and  $EA = 2$ . What is the perimeter of triangle  $CPE$ ?

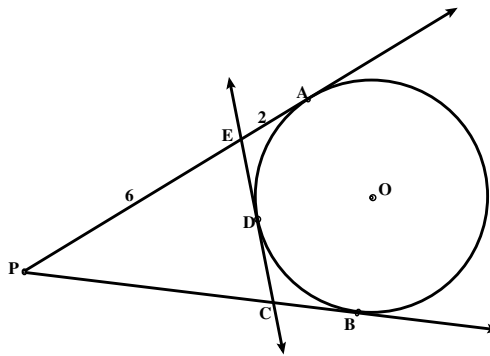

37. Squares  $ABCD$  and  $PQRS$  intersect at  $M$  and  $N$ .  $MD = 2, AM = 4,$  and  $SR = \sqrt{99}$ .  $P$  is the center of  $ABCD$ . What is the area of  $PMDN$  (the shaded region)?

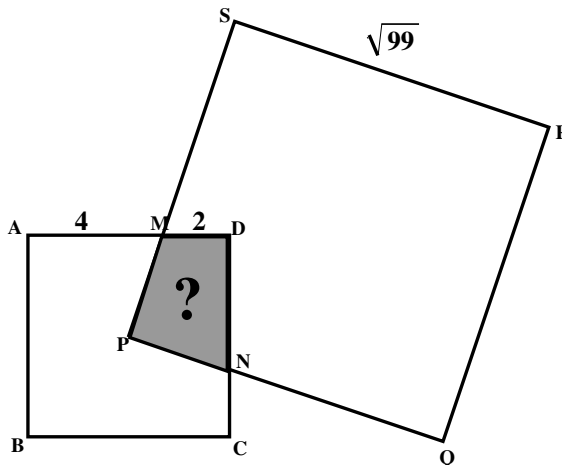

38. Let  $S = \frac{2}{24} + \frac{2}{35} + \frac{2}{46} + \frac{2}{57} + \dots$ . What is  $S$ ?

39. The side of a regular nonagon (9 sides) is  $s$ , its shortest diagonal is  $d$ , and its longest diagonal is  $x$ . Find  $s/x + d/x$ .

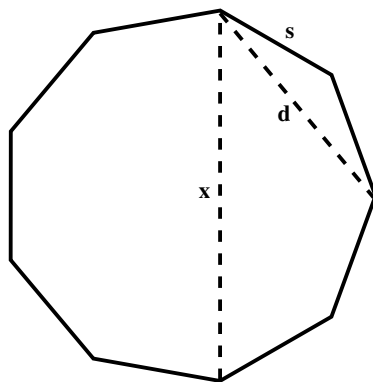

40. In triangle  $ABC$ ,  $AB = 9$ ,  $AC = 11$ , and median  $AD = 5$ . How long is side  $BC$ ?

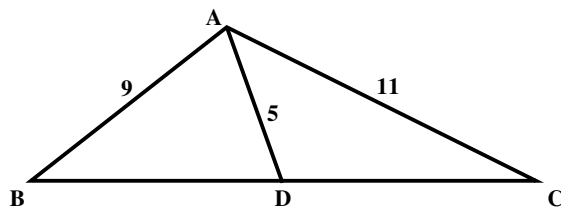

## Second Annual Math Competition

### Part I

1. What is  $\frac{16}{\left(\frac{4}{\left(\frac{3}{\left(\frac{2}{1}\right)}\right)}\right)}$  ?
2. What is the largest number of points at which a square can intersect a circle?
3. Write  $\frac{4}{37}$  as a decimal.
4. A cube has notches in 4 of its faces as shown. How many vertices (corners) does it have?

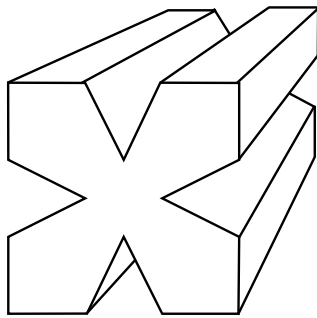

5. Lennie has rolled a fair, 6-sided die twice and has gotten a 6 both times. What is the chance that his next roll will be a 6 as well?
6. How much bigger than the sum of integers from 1 to 33 is the sum of integers from 1 to 35?
7. Name the next word in the sequence:  
p, e, pe, epe, peepe, epepeepe, ...
8. What is the largest prime factor of 1236?



9. How many paths are there from W to X which never go upward?

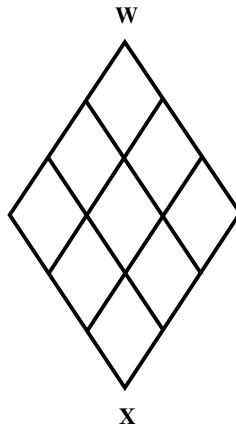

10. There are 144 square inches in a square foot, and 16 square blogs in a square foot. How many inches long is one blog?

11. How many degrees is the angle marked by the (?)?

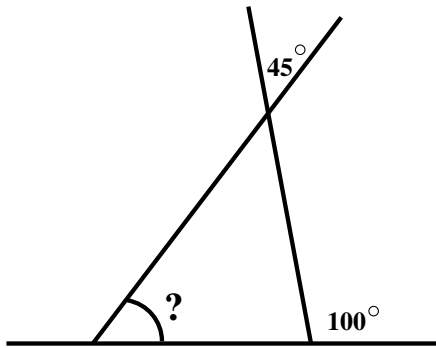

12. A certain language has two letters, D and O. How many words of 4 letters or less can there be in this language if no word has 2 D's in a row?

13. What is the greatest common factor of 448 and 450?

14. When Julius (a basketball player) extends his arms over his head, he adds 25% to his height. When Julius jumps, he increases his reach by  $\frac{1}{6}$  of his height with arms extended and he can just reach the bottom of a basketball net. If the basket rim is 10 feet high, and the net hangs 1 foot 3 inches down, how tall is Julius?

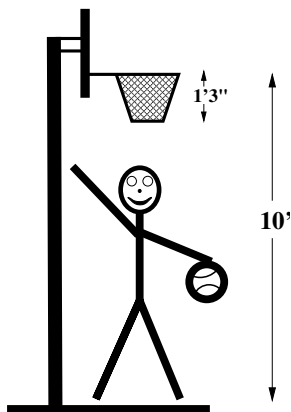

15. In a certain household, males always lie, and females always tell the truth. Three people are in the kitchen: George (male), Alice (female), and Pat (???). Someone says, "I'm George," and someone else replies, "No, you're his sister." What is the name of the person who did not speak?
16. What is  $\frac{1 \times 2 \times \dots \times 20}{-1 \times -2 \times \dots \times -20}$ ?
17. A number has remainder 1 upon division by 3, and remainder 2 upon division by 5. What is the remainder upon division by 15?
18. Myra winds her watch and sets it to 11:43, which is not the real time. She then walks down to the drugstore, looks at the clock, which reads 12:00 and realizing she has forgotten her watch, she walks home. Her watch now says 12:05. If the drugstore clock was correct, then what time should Myra set her watch to?
19.  $Y - 38$  divides evenly into  $Y - 34$ . List all possible values of  $Y$ .
20. If you flip 5 coins, what is the chance that you will get more tails than heads?

## Part II

21. If a regular octagon and two regular pentagons are stuck together, what is the angle of the gap left over?

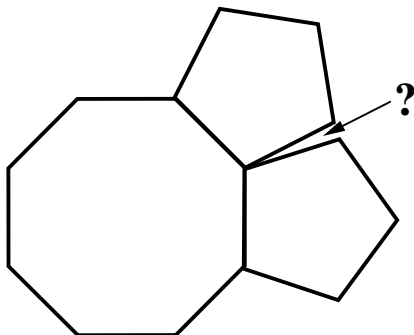

22. In a certain class, the percentage of students who have blond hair is 32% to the nearest 1%. What is the least number of students this class could have?
23. Each team has 3 games left to play against each other team. Which teams have a chance of finishing first or tied for first?

A's	30	10
BEARS	29	11
CARDS.	26	14
DODGERS	17	23
EXPOS	16	24
GIANTS	14	26

24. If  $j^2 + 17$  is divisible by  $j^2 + 4$ , and  $j$  is a positive number, than  $j = ?$
25. It takes 2 hours to fill a hot tub, and 3 hours to drain it. How long does it take to fill it if it is draining at the same time?
26. What is the next number in this sequence?  
 $6, 4, 3, 2\frac{2}{5}, 2, 1\frac{5}{7}, \dots$

27. A wallet contains 7 real \$20 bills and 2 counterfeits. If two bills fall out of the wallet, what is the chance that at least one is genuine?
28. A block has dimensions  $2 \times 3$ . If  $P$  and  $Q$  are opposite corners, then what is the distance  $PQ$ ?

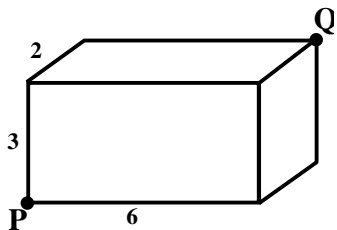

29. If  $X + Y = \frac{1}{X} + \frac{1}{Y}$ , then  $X \times Y = ?$
30. A pair of dice is rolled repeatedly. What is the chance of rolling an 8 before a 1 comes up on either die?
31.  $2^a = a^4$ . What is  $a$  if  $a > 0$ ?
32. A peanut is made out of one-quarter and three-quarter circular arcs that begin and end at the midpoints of the sides of a  $2 \times 2$  square. What is the area of the peanut?

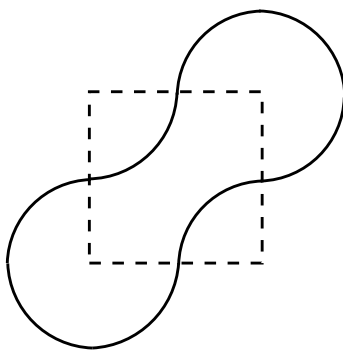

33. What is the last digit of  $7^{777}$ ?

34. A random integer is not a multiple of 6. What is the probability of that it is a multiple of 4?
35.  $2^a = 11$  and  $11^b = 16$ . What is  $3^{ab}$ ?
36. What is  $1 - .1 + 0.1 - 0.001 + \dots$ ?
37. What is the largest number which is not the sum of non-negative multiples of 7 and 8?
38. Write  $\frac{3 - \frac{2}{5}\sqrt{2}}{7 + 4\sqrt{2}}$  in the form  $\frac{a}{b} + \frac{c}{d}\sqrt{2}$ .
39. Mr. Cockroach wants to crawl from corner B to corner C by going up the roof from B to some point P, and then down the roof to C. B and C are both 3 feet from the crest of the roof which is 8 feet long. What is the length of the shortest path Mr. Roach can take?

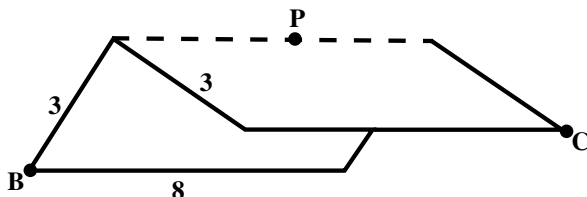

40. Richard, Spiro and Henry take turns flipping a coin in that order. The first to get a tail wins. What is the chance that Richard wins?

# Third Annual Math Competition

## Part I

1. What is  $.3 \div (.2 \div .1)$ ?
2. How many whole numbers are there between 1 and 125 whose digits sum to 7?
3. Calculate  $\frac{8}{11} \cdot (1111)$ .
4. How many triangles are in this figure?

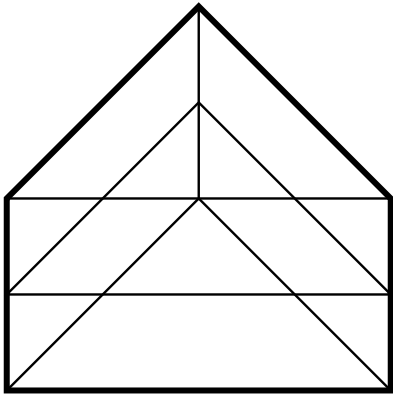

5.  $\sqrt{5^{\sqrt{4}}} = \sqrt{X}$ . What is  $X$ ?
6. A triangle has a  $130^\circ$  angle. What is the average of the other two angles?
7. What is  $1 + \frac{1}{1 + \frac{1}{1 + \frac{1}{1 + \frac{1}{2}}}}$ ?

8. A cube of side 4 has three square holes cut through it of sizes 3, 2, and 1 as in the figure. What volume remains?

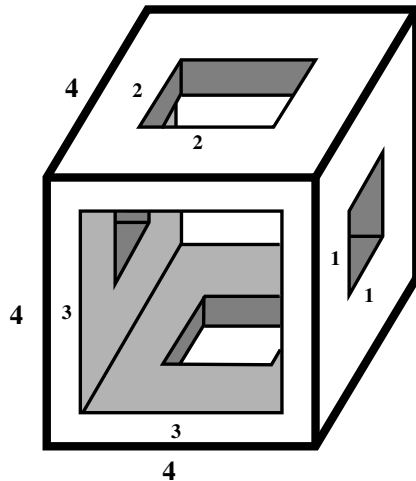

9. What digit does A represent?

$$\begin{array}{r}
 13B94A7 \\
 + 6652B8 \\
 \hline
 2054725
 \end{array}$$

10. Renée's annoying digital watch beeps twice on the hour and once on the half-hour. Since 7:15 this morning, it has beeped 19 times and will beep again in 8 minutes. What time is it?
11. Start with 7. What number do you get after going through the following cycle 17 times?

- 1) DOUBLE IT.
- 2) TAKE THE SUM OF THE DIGITS.
- 3) GO BACK TO STEP 1.

12. If  $4^a = 8$ , then what is  $16^a$ ?
13. What is the next number in the sequence: 1, 3, 7, 17, 41, ...?
14. 1 out of every 26 people is a twin. What fraction of pregnancies must result in twins?
15. Calculate  $1229^2 + 1227^2 - (2 \cdot 1229 \cdot 1227)$ .
16. Seven pennies fit perfectly on a circular plate as shown. What fraction of the plate is exposed?

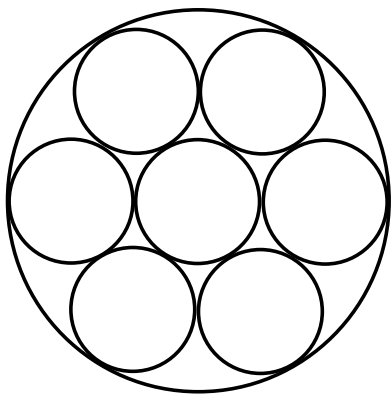

17. What is the largest 3 digit number whose only prime factors are 2 and 3?
18. Two clocks are set separately to random times. What is the probability that the clocks read within one hour of each other (ignoring AM and PM)?
19. One number is missing from this set. What number?  
 $\{1, 2, 3, 78, 39, 6, 26\}$
20.  $D = 5 \cdot 10 \cdot 15 \cdot 20 \cdot 25 \cdot 30 \cdot 35 \cdot 40 \cdot 45 \cdot 50$ . How many zeros are there at the end of  $D$ ?



## Part II

21. What is  $1 - (2 - (3 - (4 - \dots (98 - (99 - 100))))))$ ?

22. Which edge is longest?

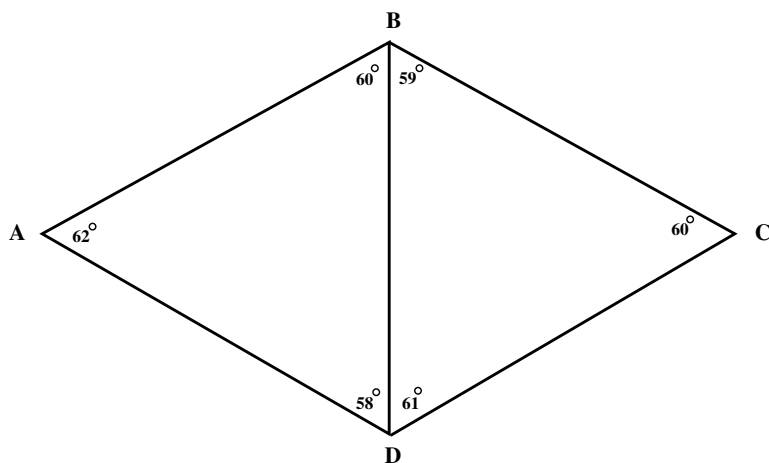

23. Next weekend's Beta-Breakers race begins at 8:00. 375 minutes later, Tyrone the Tortoise will cross the finish line. What will the angle between the hour hand and the minute hand be at that time?

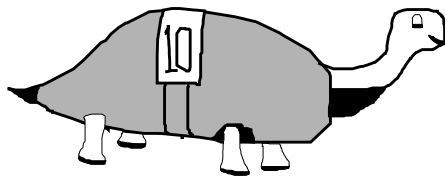

24. Montana's cube has its six faces colored red and gold only. How many different ways are there to color Montana's cube, if it can be neither all red nor all gold? (Two patterns are "different" only if one pattern cannot be rotated to get the other.)

25. If  $f + v = e + 2$ , what is  $3^f \cdot 3^v \div 3^e$ ?

26. What is the probability that the total rolled on two six-sided dice will be less than the number rolled on another single six-sided die?
27. The radius of the small circle is 43 and the triangle is equilateral. What is the radius of the big circle?

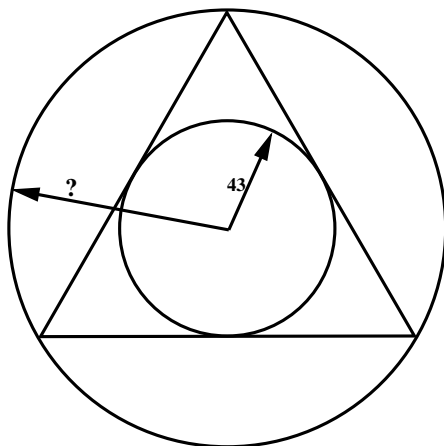

28. For how many values of  $X$  are the numbers of  $X - 40$ ,  $X - 50$ , and  $X - 60$  positive primes?
29. Find the fraction between  $\frac{5}{9}$  and  $\frac{4}{7}$  that has the smallest denominator.
30.  $Q$  and  $R$  are positive whole numbers and  $Q^2 - R^2 = 116$ . What is  $Q$ ?
31. What is the maximum number of cylindrical,  $1/2''$ -diameter pencils,  $10''$  long, that can be stuffed into a covered cigar box of interior dimensions  $4'' \times 7'' \times 10''$ ?

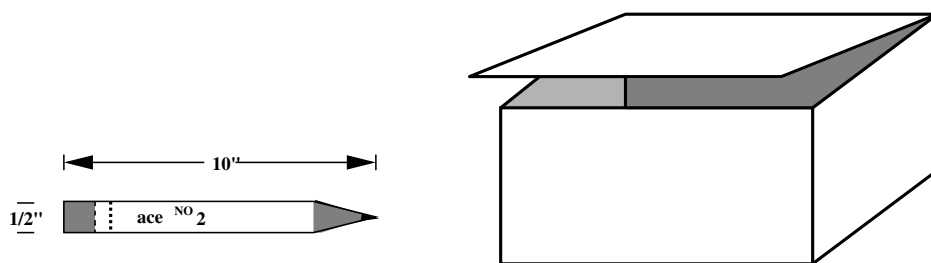

32. If one coin is flipped repeatedly, what is the probability that a run of HEADS-HEADS-HEADS will occur before a run of TAILS-HEADS-HEADS?
33. A goat is tethered to one corner of a 30x30 foot square shack with a 60 foot chain. How many square feet of grass can the goat graze on?
34. What is the sum of the digits of the product of  $7^3$ ,  $11^3$ , and  $13^3$ ?
35. Inside a regular octahedron (see figure) is a cube (not drawn) that has, initially, one vertex in the center of each face of the octahedron. If the cube is expanded so that the edges intersect the edges of the octahedron, how many faces will the resulting solid have?

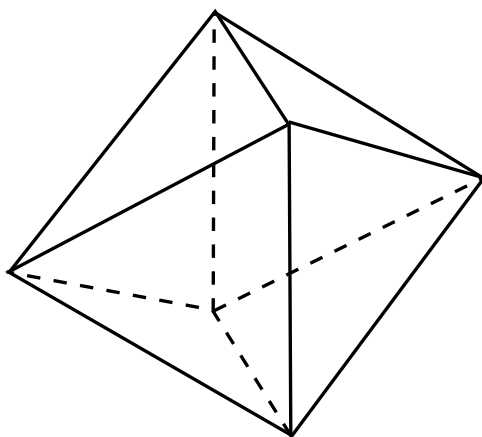

36.  $i^2 = -1$ . How much is  $(\frac{\sqrt{2}}{2} + \frac{i\sqrt{2}}{2})^{100}$ ?
37. The area of a rectangle is  $42 \text{ cm}^2$ , and its perimeter is 44 cm. How long is its diagonal, in centimeters?
38. How many numbers between 1 and 1000 have exactly 5 positive divisors?

39. Simplify this expression as much as possible:

$$\sqrt{14 + 10\sqrt{2}} + \sqrt{17 + 12\sqrt{2}}$$

40. How much Scotch tape  $\frac{1}{500}$ " thick is on a roll with outer diameter 2" and inner diameter 1"?

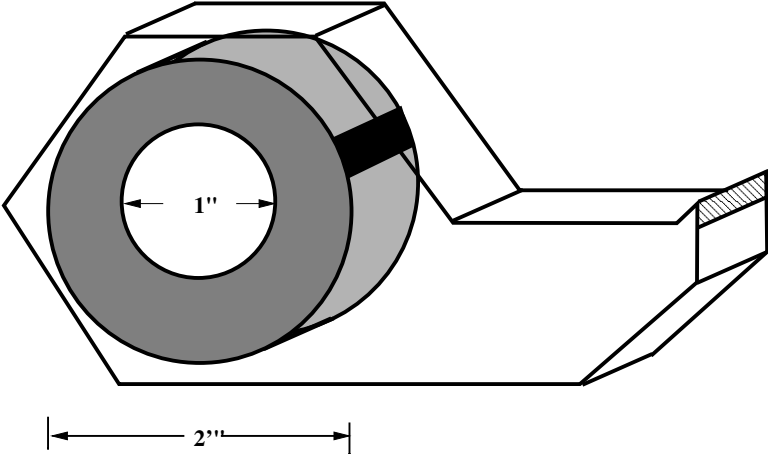

# Fourth Annual Math Competition

## Part I

1. The mileage indicator on Frances' Volkswagen reads:

**09876.5**

How many miles will she have to drive before all six digits are once again different from each other?

2. What is the maximum finite number of points at which a square of side 6 and a square of side 9 can intersect?
3. What is the sum of the integers between -59 and 61 inclusive?
4. Each side of a tetrahedron is 10 centimeters long. The shortest path along the surface connecting the midpoints of two non-intersecting edges is also 10 centimeters long. How many different 10 cm. paths are there connecting these two points?

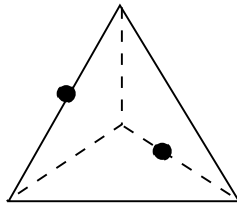

5. If you start with 9735, what number will you get after doing the steps in the box six times?

- |   |
|---|
| <ol style="list-style-type: none"><li>1. <b>Subtract 4868</b></li><li>2. <b>Double what you have.</b></li></ol> |
|---|

6. Lake Johnson is  $1\frac{2}{3}$  miles around. Joan runs 11 miles per hour, and Grete runs 10 miles per hour. If they both start running around the lake, from the same point and in the same direction, in how many minutes will Joan pass Grete?

7. The figure shows a rectangle and its diagonals. How large is the angle marked with the “?”?

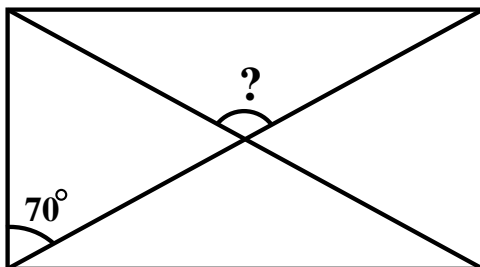

8. Calculate  $1\frac{1}{11} \times 1\frac{1}{10} \times \cdots \times 1\frac{1}{2}$ .
9. A certain number has exactly three positive divisors. How many divisors does its square have?
10. Zelda wrote down  $2^{2^2}$  but forgot to put in parentheses. How many different values are possible for this expression, depending on where parentheses are placed?
11. The minute hand of a clock has just passed the hour hand. The gap between them grows bigger at a rate of how many degrees per second?
12.  $\sqrt[3]{1,225,043}$  is a whole number. What number is it?
13. The picture on the left shows triangles placed around a point without overlapping. How many triangles identical to the one on the right could be placed in this manner?

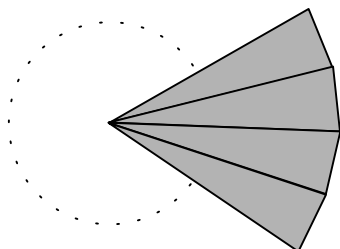

14. If a number is divisible by 7, what is the least possible value for the sum of its digits (other than 0)?
15. Uri draws two cards from a regular 52-card deck. What is the probability that the cards don't have the same rank or suit?
16. If  $5m + 11p = 14$  and  $2m - 6p = 4$ , what is  $m + 23p$ ?
17. Find the next number in the sequence:  
10, 5, 12, 7, 2, 9, 4, \_\_\_\_\_
18. What is the probability that a random integer between 1 and 423 (inclusive) is divisible by 7, but not by 6?
19. Find the only integer value of  $x$  so that  $x^5 + 2x^4 + 4x^3 + 8x^2 + 16x + 32 = 0$ .
20. How many 2 inch wide rings,  $\frac{1}{4}$  inch thick, are necessary to make a 6 foot link chain?

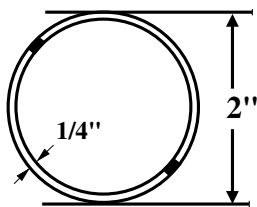

## Part II

21. What is the last digit of the product  $2^1 \times 2^2 \times 2^3 \times \dots \times 2^{10}$ ?
22. The answer to problem number  $p$  in this competition is 22. What is  $p$ ?
23. What is the minimum number of **T**-shaped tiles, overlapping if necessary, that it takes to cover the board?

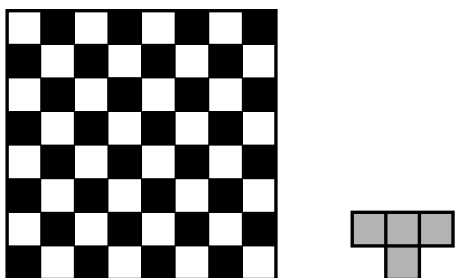

24. How many possible values are there for the expression:

$$\pm\sqrt{1 \pm \sqrt{13 \pm \sqrt{144}}}$$

25. A tray contains 5 pounds of green slime, which gradually quadruples in size every 3 hours. How much slime was there  $7\frac{1}{2}$  hours ago?
26. In the sequence **64, 8, 4,  $2\sqrt{2}$ ,  $2\sqrt[5]{2}$ , 2**, \_\_\_\_\_, what goes in the blank?
27. A cube sits alone in space. What is the maximum number of cubes identical to it that can be placed so that they all touch the original cube, if touching at just an edge or corner doesn't count?



28. Freddy's racket has an inside diameter of 10 inches, and strings 1 inch apart. What is the total length of the string shown, to the nearest foot?

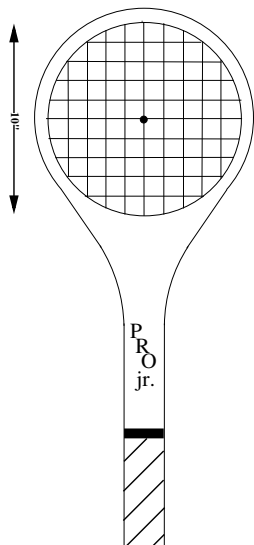

29. How many squares of integers are there between  $9687$  and  $9688 + 2\sqrt{9687}$ ?
30. What is the first number greater than  $500,000$  in this sequence?

$$1, 3, 6, 10, 21, \dots$$

31. We want to cover a tomato with a square of untorn plastic wrap. If the tomato has a radius of one inch, how long must the edge of the square of plastic wrap be?
32. What is  $8 \times \sqrt{8} \times \sqrt{\sqrt{8}} \times \sqrt{\sqrt{\sqrt{8}}} \times \dots$ ?
33. The divisors of  $120$  add up to  $360$ . What is the sum of the reciprocals of the divisors of  $120$ ?
34. At San Leandro High School,  $76$  students like algebra,  $63$  like music,  $57$  like ice cream,  $21$  like algebra and music,  $17$  like algebra and ice cream,  $13$  like music and ice cream, and  $5$  actually enjoy all three. One student doesn't like any of these. How many students are there?

35. Edith cuts a corner off of a one inch square. How long must the cut  $\overline{BC}$  be so that  $\overline{BC} = \overline{AB} = \overline{CD}$ ?

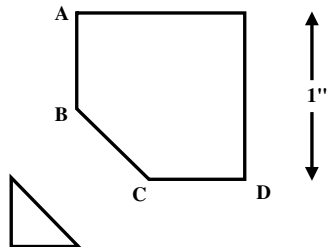

36. What is the area, in square inches, of the crescent shown above on the right? The X's indicate the centers of the arcs bounding the crescents.

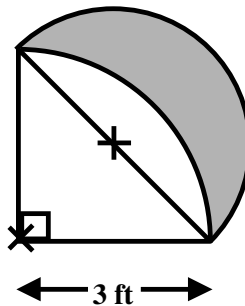

37.  $x, y,$  and  $z$  are all integers, and  $(\sqrt{2} + \sqrt{3})^8 = x + y \cdot \sqrt{z}$ . What is the least possible value of  $z$ ?
38.  $A00A = BB \times CC$ . Each different letter stands for a different digit. What digit does B stand for?

39. What is the area of a triangle whose sides have length 1,  $\sqrt{26}$ , and  $\sqrt{37}$ ?
40. If A, B, and C are points of tangency, how many inches wide is the gap marked with the “w”?

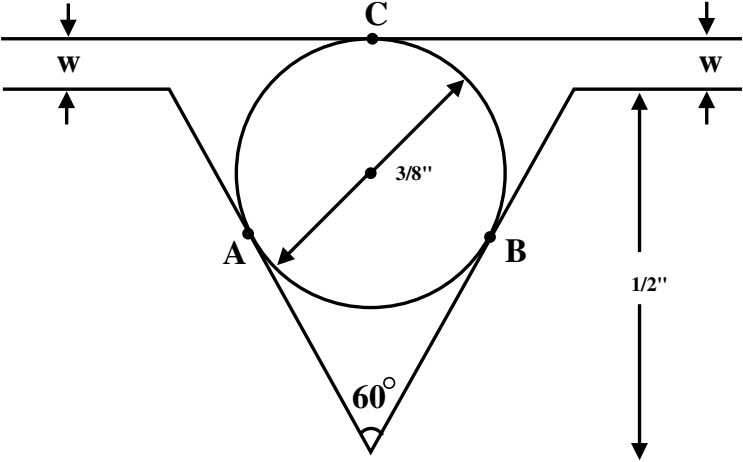

# Fifth Annual Math Competition

## Part I

1. How many positive whole numbers are there less than 10,000 whose digits add up to 2?
2. May 12, 1984 is a Saturday. May 12, 1985 will be a Sunday. What day of the week will May 12, 1992 fall on?
3. One arrow points southeast and the other points between north and northeast. What is the angle between the arrows?

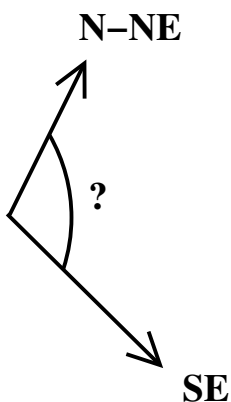

4. Calculate  $\frac{172666582}{9} + \frac{827333417}{9}$ .
5. When 3 coins are flipped, what is the chance that they will all match?
6. Calculate  $\left(3\frac{1}{2}\right)^3 \times \left(\frac{2}{7}\right)^4$ .
7. A triangle and a rectangle overlap so there is a region inside both figures. What is the greatest number of sides this region could have?

8. The picture shows a quarter-pyramid 3 levels high that contains 10 cubes. How many cubes are there in one 7 levels high?

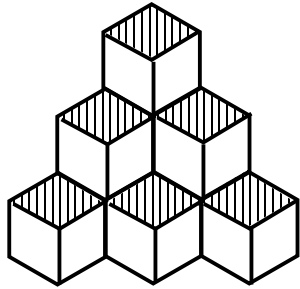

9. What is the maximum number of trees that can be planted so that each tree is the same distance from every other tree?
10. How many seconds are there in  $\frac{1}{3600}$  of a day?
11. **A** and **B** are integers, and  $\mathbf{A^B = B^A + 6}$ . What is **A**?
12. In how many ways can you pick three different numbers from the following set so that their product is 72?

$$\{1, 2, 3, 4, 6, 8, 9, 12, 18\}$$

13. 15 people are waiting in line. Everyone is either always truthful or always a liar. Each person says, "Everyone ahead of me is a liar," except the first person who is silent. How many liars are there?

14. A square is cut up as shown, so that the two arrows have the same length. Three of the pieces can be fit together to make a smaller square. Which three?

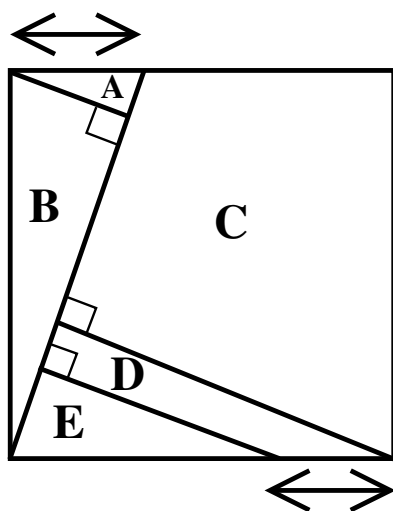

15. There is a book that has 420 pages. How many times does the digit 6 appear among the page numbers?
16.  $2^{1000}$  has  $d$  digits. How many digits does  $d$  have?
17. Here are two related sequences. What is the next term in the second sequence?  
 1, 3, 6, 10, 15, ...  
 1, 4, 10, 20, 35, ?, ...
18. Kareem found \$20 on the street and he now has 5 times as much money as he would have if he had lost \$20 instead. How much did he have before his lucky moment?
19. The product of two positive integers is 1,000, but neither of the numbers has a 0 for any of its digits. What is the sum of the two numbers?
20. Carmen writes a multiplication table up to 6 times 6. What is the sum of all 36 entries?

## Part II

21. What positive number is three times the sum of its digits?
22. If you start with a certain prime number, add 64 and take the square root, you get a whole number. What prime must you start with?
23. Quong's clock reads 5:43. When is the next time the angle between the two hands will be the same as it is now?
24. The two disks shown have 6 holes cut in them but some of the holes are plugged up (shaded). They are spun randomly and stacked on top of each other so that the holes line up. What is the probability that two unplugged holes line up somewhere so you can see through the disks?

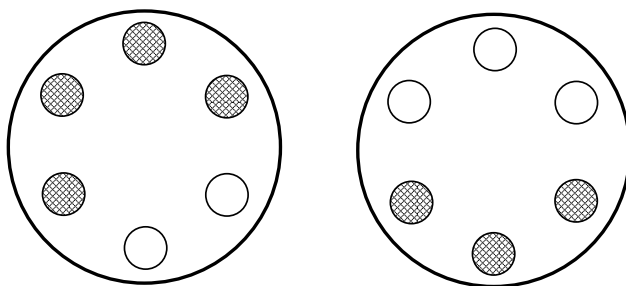

25. How many iron balls 1 inch in diameter are needed to balance a 2-inch ball and a 3-inch ball?
26. Simplify  $\frac{20!}{19! - 18!}$  to lowest terms. (The “!” after a number is an abbreviation meaning the product of all the numbers up to that number. For example,  $5!$  stands for  $1 \times 2 \times 3 \times 4 \times 5$ .)

27. Right triangles A, B, C, and D fit inside a square as shown. They all have hypotenuse (longest side) equal to 12, and the difference between the lengths of the other sides equal 4. What is the area of A?

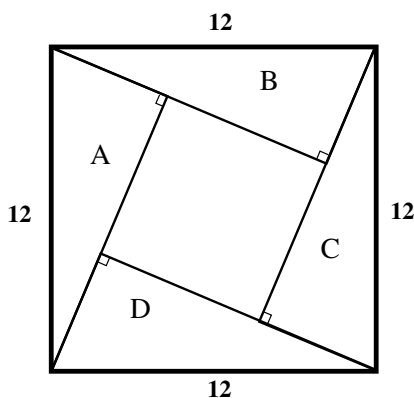

28. How many positive integers give a remainder of 6 when divided into 105?
29. Suppose families with 1, 2, 3, and 4 children are equally common, and no family has any other children. A questionnaire asks children how many siblings (brothers and sisters not including oneself) each child has. What will the average be?
30. What is the least positive integer,  $N$ , for which  $12 \times N$  is the cube of another whole number?
31. Calculate

$$\sqrt{\sqrt{\sqrt{32^{3.2}}}}$$

32. 100 slips of paper numbered 1 to 100 are shuffled. Then Nero picks two of them and Oren picks one. What is the probability that one of Nero's numbers is higher than Oren's and the other is lower?



33.  $X - \sqrt{X} = \sqrt{X - X \times \sqrt{X}}$ . What is  $X$  if  $X > 0$ ?
34. 4 eggs cost the same as 5 apples. 2 eggs and an apple cost the same as a popsicle. How many apples cost the same as 22 eggs and 3 popsicles?
35. How many 10-letter combinations of A's and B's come before AAAABAABAB in alphabetical order?



36. A girl whose eyes are 1 meter high stands on an asteroid. She sees the horizon 700 meters away. What is the diameter of the asteroid?

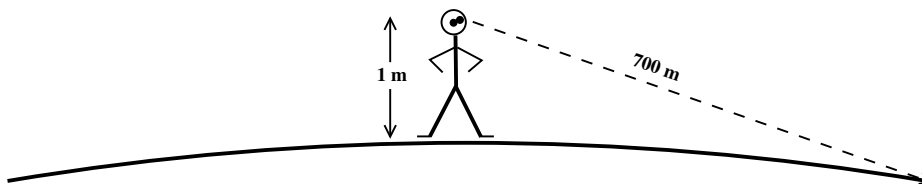

37. Kim writes down three 2-digit numbers, and all six digits are different. In order to make the product of the numbers as large as possible, which three numbers should Kim write down?
38.  $\frac{1}{89}$  is a repeating decimal that begins .0112359... . What is the last digit before the 0112... repeats?

39. Jill chooses randomly one of the two decks in front of her and selects a card from it, also at random. It is the ace of spades. If one of the decks was a normal 52-deck card, but the other was a trick deck containing only aces of spades, what is the chance that Jill picked the trick deck?
40. If the three dots are the centers of the circles and each circle has radius 1, what is the area of the shaded regions common to all circles?

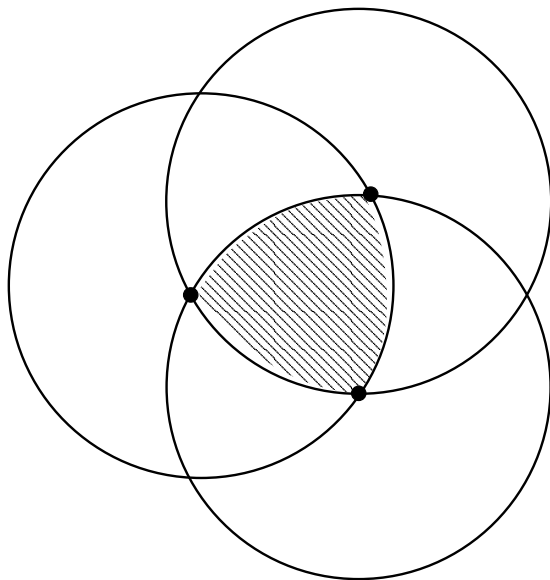

# Sixth Annual Math Competition

## Part I

1. Calculate  $\frac{1}{2222} - \frac{1}{3333}$ .
2. If A, B, and C represent three different digits, what digit does B represent?

$$\begin{array}{r} 3A \\ \times 3B \\ \hline CCB \end{array}$$

3. How many different positive prime numbers divide evenly into 321000?
4. It is a 5 hour bus ride from Oakland to Truckee and a bus leaves every 20 minutes. If one of the buses waits 5 minutes in Truckee and then goes back to Oakland, how many buses will it pass on the way back?
5. What fraction of the triangle PQZ is shaded if all the triangles shown are equilateral?

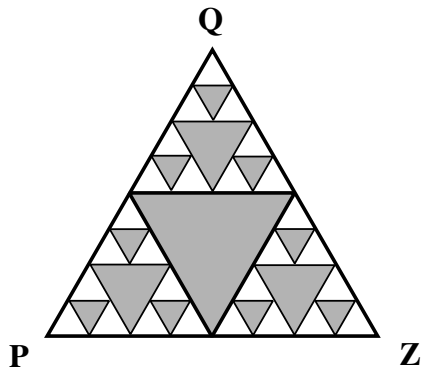

6. What number comes before .1 in this sequence?  
\_\_\_\_, .1, .45, .8, 1.15, ...

7.  $3^3 + 7^3 + 0^3 = 370$ . Find another three digit number that is equal to the sum of the cube of its digits.
8. What is the sum of all prime numbers between 45 and 60?
9. The United Kingdom of Uuzbek has coin values of 1, 5, 8, 10, and 50 scruds. What is the least number of coins needed to make the amount of 84 scruds?
10. The grid in the picture is 20 by 20. What is the maximum number of dots in the grid that a single straight line can pass through if it cannot be vertical, horizontal, or a  $45^\circ$  line?

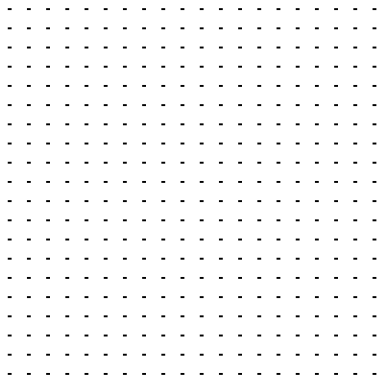

11. What is the last digit of the product  $17 \cdot 19 \cdot \dots \cdot 31 \cdot 33$ ?
12. How many whole numbers greater than 0 cannot be gotten by adding together  $1\frac{1}{2}$ 's and  $3\frac{1}{2}$ 's?
13. A Ferris wheel rotates  $48^\circ$  from one stop to the next. How many times must it stop in order to get back in its original position?

14. A gurf can move on a large checkerboard, either one square up and two to the right, or two squares up and one to either side. What is the least number of moves in which a gurf can travel precisely 10 squares up and 10 squares to the right?

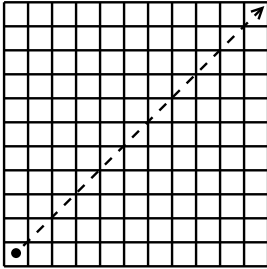

15. 12 four letter words have a certain property. The list below contains 11 of them. Which one is missing?

**ADBC**  
**CABD**  
**CADB**  
**ABCD CDAB**  
**ABDC DABC**  
**ADBD DACB**  
**ACDB DCAB**

16. Zola Budd runs a mile in 4 minutes and 20 seconds. The mile is 4 laps and she runs each lap 2 seconds slower than the one before. How long does it take her to run the first lap?

17. A soccer ball and a tennis ball are sitting on the floor and a triangular block of wood is wedged between them. If the distances between points of contact are as shown in the picture, what is the distance JK between the bottoms of the balls?

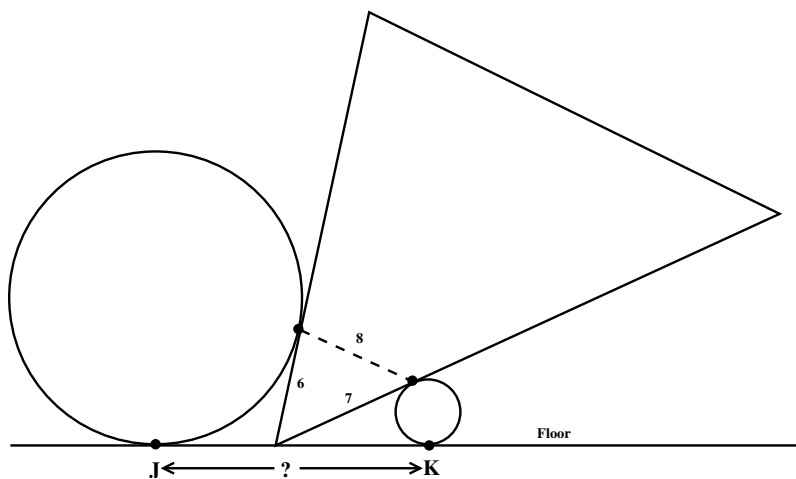

18.  $w$  and  $s$  are positive whole numbers and  $ws + s^2 = 53$ . What is  $w$ ?
19. Freddie is driving his 29 foot Cadillac down the dashed line in the middle of the road. The dashes are 4 feet long and there is a 50 foot space between the dashes. If Freddie stops suddenly, what is the probability that part of his car will cover at least part of a dash?

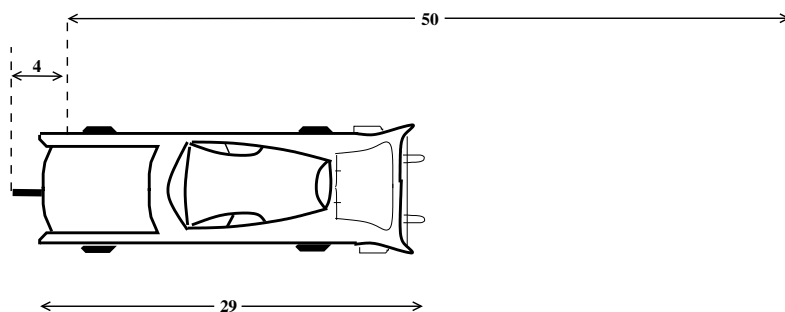

20. A triangle has area 30. Connecting the midpoints of the sides of this triangle gives a second triangle. What is the area of the second triangle?

## Part II

21. Using only three 4's and as many of the symbols  $+$ ,  $\cdot$ ,  $-$ ,  $\div$  and decimal points as you need, write an expression equal to 110. (Example: for an expression equal to 48, you could write  $44 + 4$ .)
22. What angle does the extended side make with the horizontal dotted line if the figure is a perfect 5-pointed star?

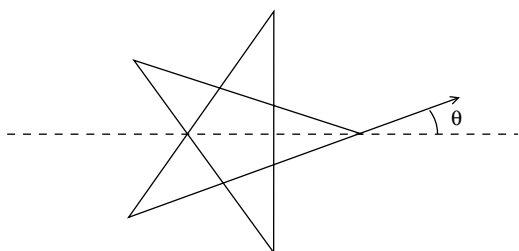

23. How many two letter combinations can be formed using one vowel and one consonant, if any occurrence of the letter "Y" can be counted as either?
24. Calculate:  
 $(12345678 + 4) \cdot (12345678 + 6) -$   
 $(12345678 + 2) \cdot (12345678 + 8).$
25. Two circles of radii 4 and 11 are centered at  $x$ . How long is the longest straight path that can be drawn in the shaded region between the two circles?

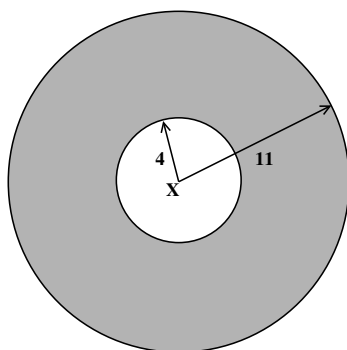

26.  $M$  is a positive whole number having exactly 7 positive divisors.  $M + 1$  has exactly 8. What is the smallest possible value for  $M$ ?
27. How many different shapes can be constructed by connecting 4 identical regular hexagons, always along an entire edge? Shapes that can be gotten from each other by rotating and reflecting, such as these, are not counted as different

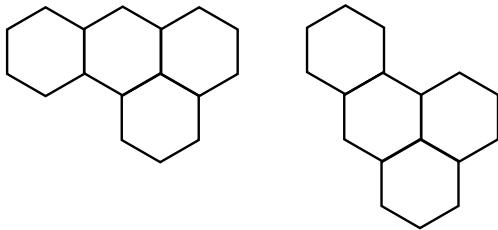

28. The new AT&T supersaver price for a one minute call to Albania is 1¢ for each degree between the hour and the minute hands of a clock showing the time at which the call started. If people call Albania at random times all day long, what will be the average price of a one minute call?
29.  $\sqrt{6} + \sqrt{2} = \sqrt{Q + 4\sqrt{3}}$ . What is  $Q$ ?
30. 13 senators are seated in a row to take a vote. After the votes are counted, it turns out that each senator voted NO if exactly one of the senators next to him voted YES, and voted YES if zero or two people next to him voted YES. How many of the senators voted YES?
31. The corner of a 1 by 1 cube has volume  $\frac{1}{6}$  as shown. What is the volume of a tetrahedron all of whose sides have length  $\sqrt{2}$ ?

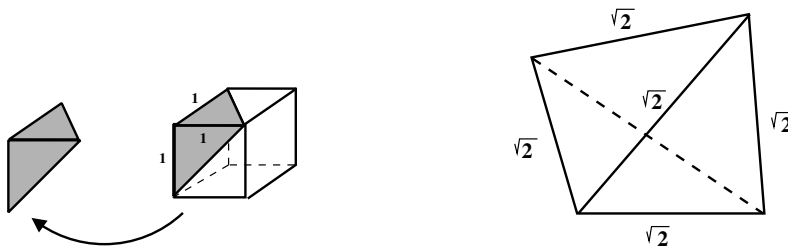



32.  $\sqrt{4^{4^4}}$  is a whole number. So is  $\sqrt{\sqrt{4^{(4^4)}}$ . Starting with  $4^{(4^4)}$ , how many times must you take the square root in order to get something that is not a whole number?
33. What is  $\frac{1}{2} + \frac{2}{4} + \frac{3}{8} + \frac{4}{16} + \frac{5}{32} + \dots$ ?
34. The earth goes around the sun once in a year, while APOLLO XXXVIII goes around the earth (in the same direction) 3 times a year. If they start in a line, how long will it be until they are all in a line again?

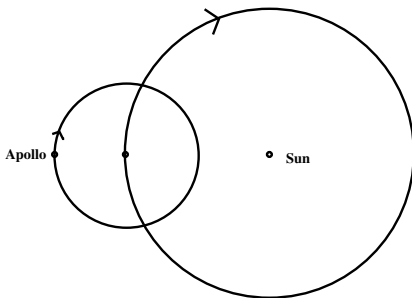

35. What is the least possible value for  $x^4 + (x + 1)^4$  if  $x$  can be any real number?
36. Rose and Gilda are playing a game where they flip a coin and the loser pays the winner \$1. They play until one of them is broke. If Rose starts with \$3 and Gilda starts with \$1, what is the chance that Rose will go broke?
37. What is the maximum area in which a disk of radius 1 and a 1 by 17 rectangle can intersect?
38. R is the integer for which  $R \cdot (\sqrt{83} - \sqrt{82})$  is closest to 1. What is R?

39. A U.F.O. hovers above Quito on the equator at 1:00. By 2:00 it is over a different city because the earth has rotated. How far is the trip by car between the two cities if the radius of the earth is 6400 kilometers?

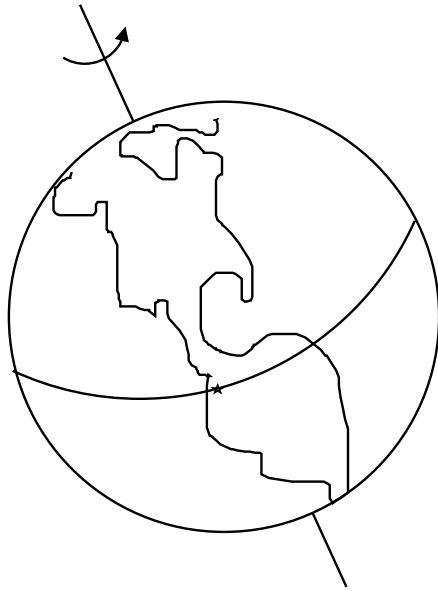

40. The Fibonacci sequence begins 1, 1, 2, 3, 5, 8, 13, 21, 34, ... and each number is the sum of the previous two. The 16<sup>th</sup> and 17<sup>th</sup> both end in a 7. What digit does the 450<sup>th</sup> Fibonacci number end in?

# Seventh Annual Math Competition

## Part I

1. Calculate the quotient  $(5689^2 - 1) \div 5688$ .
2. What is the sum of all prime numbers between 110 and 120?
3. Akeem's new Calculator has a  $\frac{1}{1-x}$  button. Pressing this button automatically changes the displayed number by subtracting it from 1 and then taking the reciprocal. How many times must Akeem press the  $\frac{1}{1-x}$  button to get back to the number he started with?
4. Akeem wants to color in this design with red, yellow and blue so that the regions that touch get different colors. If he begins as shown, what are all his possible choices for the color of the region on the far left?

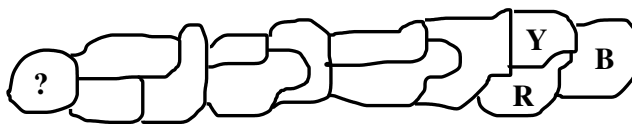

5. How many coins of radius 1 inch can you lay flatly inside a circle of radius 3 inches so that no coin touches any other coin?
6.  $41 \cdot 271 = 1111$ . What is  $123 \cdot 542$ ?
7. The people on Sesame Street all decide to buy new house numbers, so they line up at the store in order of their addresses: 1, 2, 3, ... . If the store has a supply of 100 of each digit, what is the first address that won't be able to buy numbers for their house?

8. How many ways can you move from the point on the left to the dotted line on the right by making 3 moves along the connecting lines or arcs?

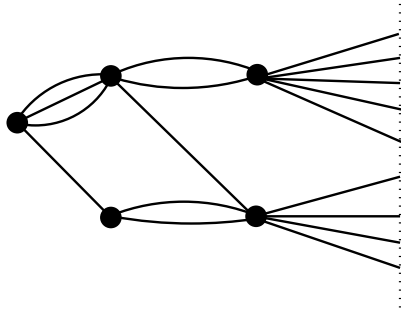

9. Which of these three numbers has the most divisors?

**800, 900, 1000**

10. Cantor, Godel, and Smullyan each always lie or always tell the truth. Cantor says “Godel tells the truth,” and then one of the three writes a note saying, “Cantor is a liar.” Who wrote the note?
11. A fair, six-sided die is rolled until two different numbers have come up. What is the probability that they are both even?
12. Denebians from outer space have 3 heads and 47 legs. At the first meeting between humans and Denebians there were 106 legs. How many heads were present?
13. If we have one weight of 1 ounce, one weight of 4 ounces, and one weight of 11 ounces, how many different amounts can we weigh if weights can be put on either pan?

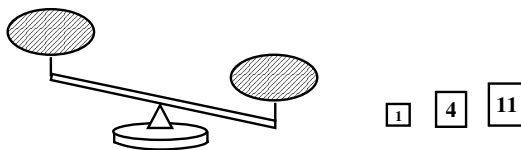

14. Dierdre the Denebian has a drawer full of 100 red socks and 100 blue socks. If she isn't looking, how many socks must she pull out of the drawer in order to be sure she has at least 47 socks of one color?
15. At the Denebian Auto Expo, there are 81 cars: Fords, Jaguars, and Volkswagens. There are half as many Fords as Volkswagens and the number of Jaguars is 80% of the number of Fords and Volkswagens together. How many Fords were at the Expo?
16. 2, 4, 8, 61, 23, 46, 821, 652, 215,    ? , ...  
(What number comes next in the sequence?)
17. If  $r \clubsuit a$  means  $r^a - a^r$  and  $n \heartsuit k$  means  $nk - n$ , then what is  $3 \clubsuit (4 \heartsuit 2)$ ?
18. A legal move in Denebian checkers is to jump any checker over a checker next to it into an empty square and remove the checker that was jumped over. If checkers A, B, C, D and E are placed as shown, which of them can get to square Z within 4 moves?

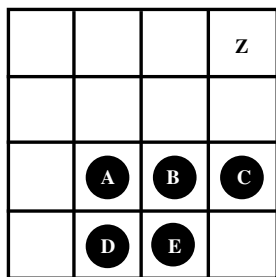

19. A sequence of five numbers starts with a 4 and ends with a 53. Each term in the sequence is the sum of the previous two. What is the third number in this list?

20. Dierdre's clock is like a normal clock except that the hour hand moves backwards. Starting at noon, how many minutes will it take until the hands are 130 degrees apart?

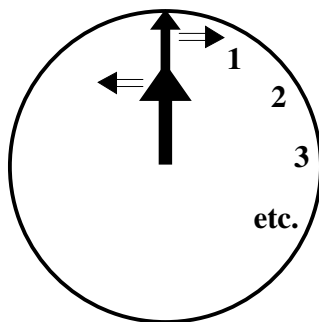

## Part II

21.  $\frac{3}{23} = \frac{1}{A} + \frac{1}{B}$  where  $A$  and  $B$  are positive integers. What are  $A$  and  $B$ ?
22. Four sticks of length 1, 2, 2 and 3 are fastened together as shown. What are the smallest and largest possible angles between the two sticks of length 2?

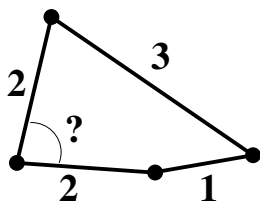

23. The rental charge for large, medium and small diving masks are \$3, \$2, and \$1 respectively. A special deal offers any 5 diving masks for \$8. How much does it cost to rent 4 large, 8 medium and 3 small masks in the cheapest way possible?
24. If two spheres whose centers are 50 feet apart have radii 40 feet and 30 feet, what is the diameter of the circle of intersection?

25. What is the angle marked ? in the picture to the right?

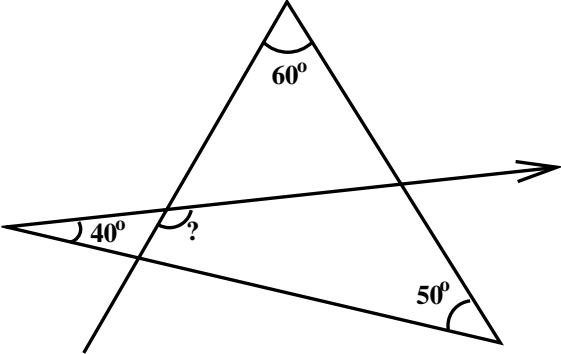

26. The whole numbers from 93 to 101 are placed in a 3x3 array so that each row and also each column adds up to the same number. What number?

27. A circle with an arrow rolls around a compass twice its size. If it begins at the north of the compass with the arrow pointing north, and rolls without slipping to directly east of the compass, what direction will the arrow point?

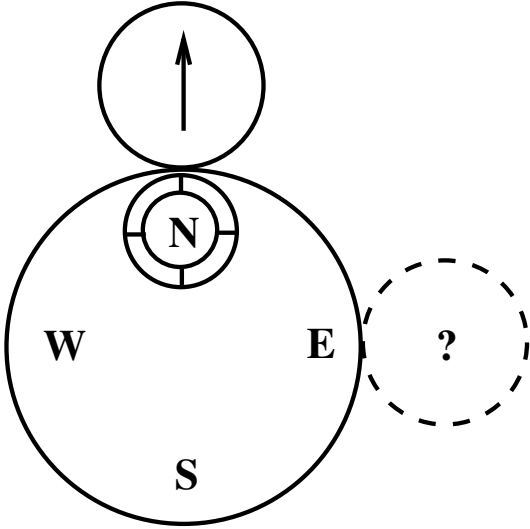

28. Elwyn and Bronwyn take turns moving a marker along the arrows, and whoever moves to the W wins. If Elwyn goes first and the marker begins at the circle, which of the three moves B, P or C guarantees a win for Elwyn?

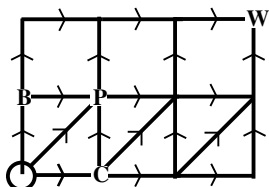

29. If  $\sqrt{m} + \sqrt{n} = 13$  and  $m$  and  $n$  differ by 65, what is the largest possible value for  $m$ ?
30. What is  $\frac{1}{2!} + \frac{2}{3!} + \frac{3}{4!} + \cdots + \frac{49}{50!}$ ?
31. A straight road runs tangent to a circular pond of radius 1 km. If Sharon drives 1 km along the road, how far is she from the nearest side of the pond?

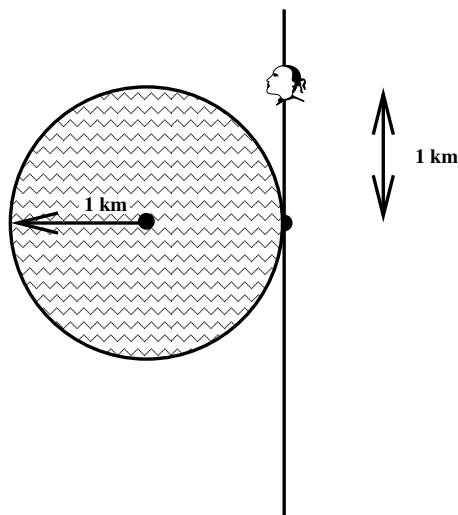

32. Pat beats Lynn in a footrace 60% of the time. If they decide to race “best 2 out of 3” so the first to win 2 races is the winner, what is the chance that Pat wins?



33. If the numbers from one to ninety-nine thousand nine hundred ninety-nine are spelled out and written in alphabetical order (ignoring hyphens), what comes right before 11?
34. In a certain base, this is a true equation, with some of the digits replaced by strawberries. What is the base?

$$(2 \text{ 🍓 } 3) (2 \text{ 🍓 } 5) = 1 \text{ 🍓 } \text{ 🍓 } \text{ 🍓 } 3$$

35. What is the area of the space between three kissing circles, if the radii of all circles is  $\mathbf{R}$ ?

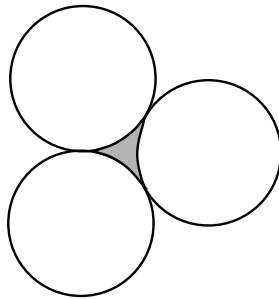

36. 4% of all clovers have 3 leaves, 46% have 4 leaves, 46% have 5 leaves, and 4% have 6 leaves. How many leaves are there in an average sample of 20 clovers?
37. Bermuda Triangle Airlines' new logo is a partly-shaded equilateral triangle. The  $\mathbf{T}$  is in the center of the triangle, angle  $\mathbf{BTA}$  is 120 degrees and  $\mathbf{B}$  is 4 times as far from the top as  $\mathbf{A}$  is. What fraction of the triangle is shaded in?

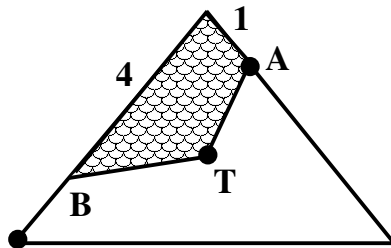

38.  $V$  is a function that counts how many positive 1-digit divisors a number has. For example,  $V(100) = 4$  because the 1-digit divisors of 100 are 1, 2, 4 and 5. What is  $V(100) + V(99) + \cdots + V(1)$ ?
39. If  $3^s = 4$  and  $4^x = 8$ , what is  $9^{s-x}$ ?
40. Mt. Zeus has the shape of an upside-down cone. Walking around the mountain from A to B takes two miles. Walking from A to the top and back down to B also takes 2 miles. What is the length of the shortest walk from A to B, to the nearest 1/10 mile?

